

Start Here

▼ Installing your Microtek ArtixScan 1200DF

Step 1

Unpack Contents

Unpack your scanner package and check for major components.

1. ArtixScan 1200DF scanner
2. Power adapter
3. Black mat
4. Software CDs/DVDs
5. Power cord
6. Hi-Speed USB cable

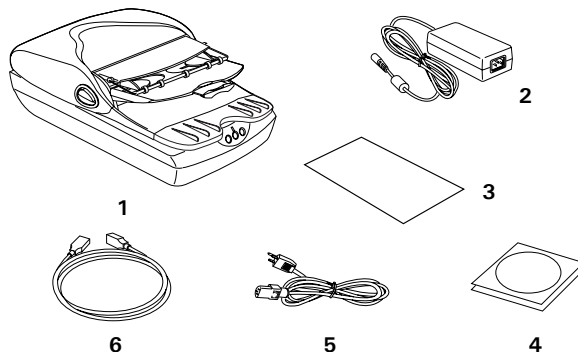

Step 2

Install Software

Important: Do not remove the yellow stickers from your scanner until you are told to do so. You must install software before connecting your scanner.

Always close any open programs and turn off Anti-virus utilities before installing software.

- A. Turn on your computer.
- B. Place the **Microtek Software CD/DVD** into a drive, and follow the on-screen instructions to install the scanner driver and software.
- C. Restart your computer at the end of all software installation.

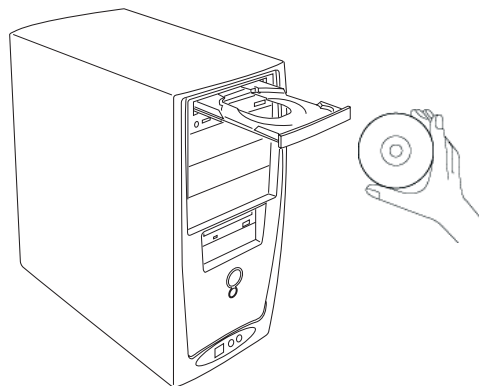

NOTE: If the Microtek Software Installer screen does not come up automatically, double-click the following in succession: "My Computer"; the CD/DVD-ROM icon; then cdsetup.exe to start the installer program.

Step 3 Unlock Scanner

- Remove the yellow "Step 3" sticker from your scanner.
- With the scanner power off, tilt the front right corner of the scanner to see the locking switch at the bottom.
- Pull the carriage lock protector (ivory white in appearance) out.
- Push the locking switch to the position as indicated in the graphic above, with the icon on the lock showing as "unlocked".

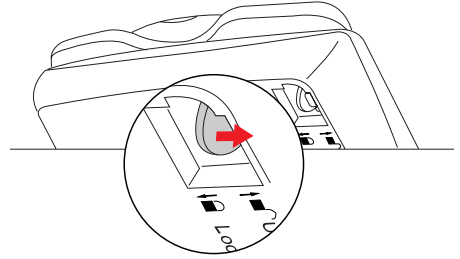

Unlocked

NOTE: To lock the scanner (for shipping and other reasons), refer to the ArtixScan 1200DF User's Manual.

Step 4 Connect Scanner

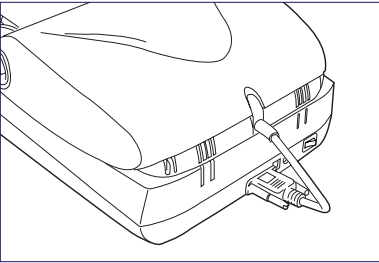

To the ADF

Make sure the Automatic Document (ADF) is properly installed, with its connector securely connected to the scanner's 15-pin accessory port.

To the power adapter

- Remove the yellow "Step 4" sticker from your scanner.
- Connect the power adapter to the back of the scanner.
- Plug one end of the power cord into the power adapter, and plug the other end of the power cord into a wall outlet or other power source.

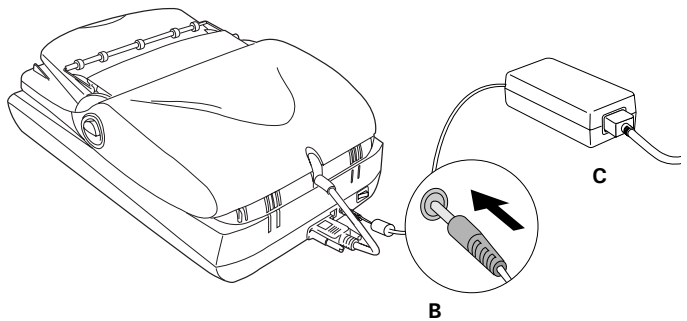

Step 4: Connect Scanner (cont.)

To the Hi-Speed USB cable

- D. Connect one end of the cable to your computer.
- E. Connect the other end of the cable to the scanner's USB port.

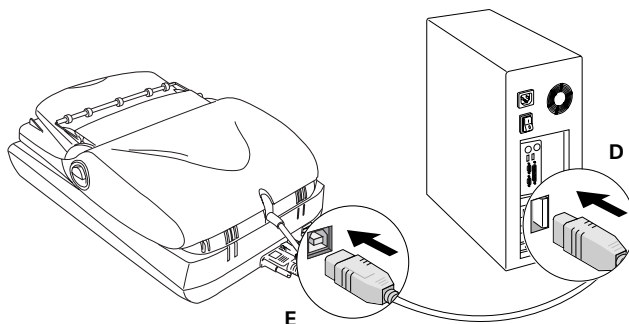

- F. Turn the power switch at the back of your scanner to "On", and wait for the light to stop blinking and stay on steady.

The system will detect your scanner automatically.

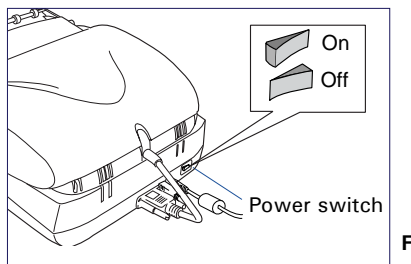
**Customize the Function Buttons**

The ArtixScan 1200DF is equipped with 3 programmable function buttons (F1, F2, and F3) that can be customized to automate a number of predefined operations, such as scanning to a file, sending an image to your printer, scanning for OCR, etc. Customizing is done through the *Save Settings to Function Button* command in the ScanWizard DI, refer to the ArtixScan 1200DF User's Manual for more details.

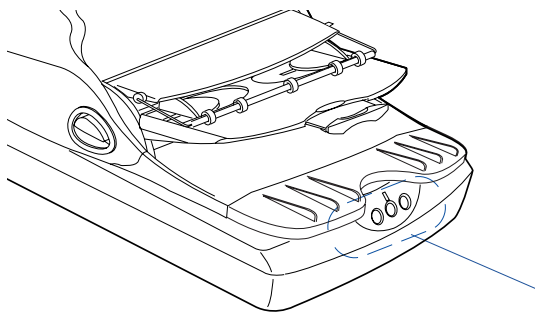

- **F1, F2, and F3:** Customizes the function buttons to perform your preferred functions.

3 programmable function buttons

F1 F2 F3

Position a Stack of Documents

A stack of up to 50 documents can be fed in the Document Feed Tray of the Automatic Document Feeder (ADF). Document sizes can range from 4.14" x 5.83" (105 mm x 148 mm) to 8.5" x 25" (215.9 mm x 635 mm).

1. Raise the Scanner Lid, and remove the ADF's protective film from the cover of the scan area. Close the lid.
2. Pull out the top Tray Extender for better paper support if the length of the originals exceeds 10 inches.

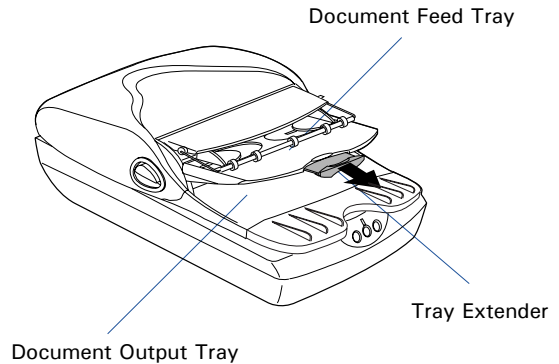
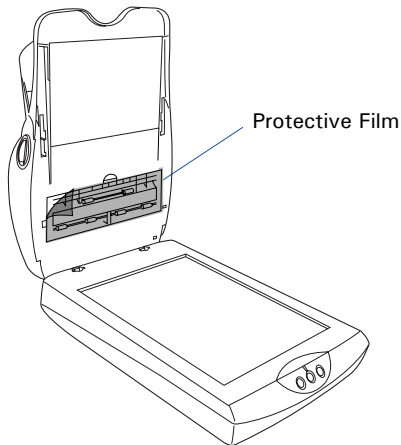

3. Open the top Tray Flap and load the stack of originals on to the Document Feed Tray, with the side to be scanned facing up. Push the stack of papers into the tray, until the paper's edges touch the feeder rollers.
4. Align the material with the center of the Document Feed Tray by sliding the two Guide Arms toward the stacked sheets if the width of the originals is less than 8.5 inches.

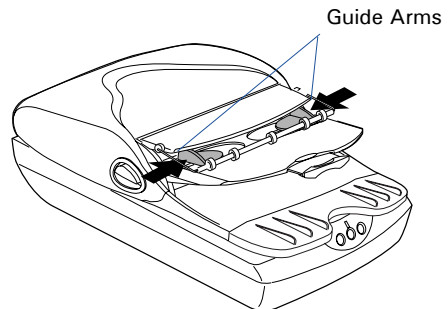
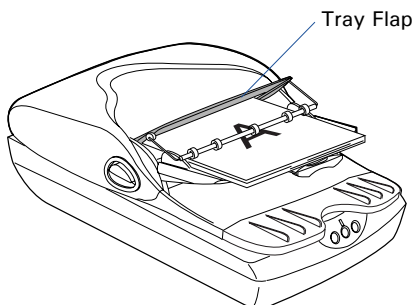

WARNING: The document feeder is not designed for scanning photos; doing so may damage your originals. Microtek accepts no responsibility for damage that may arise from misuse of equipment.

Scan a Stack of Documents

1. Place the stack of documents to be scanned on the Document Feed Tray of the Auto Document Feeder (ADF).

WARNING: Do not place photo paper or fragile sheets of paper on the feed tray, as doing this will damage the original photo or frail papers during the feeding process. Always place frail originals on the scanner glass surface, and choose “Flatbed” as your “scan source.”

2. Launch ScanWizard DI — either as a stand-alone by clicking the program icon, or by using the *File-Import* or *Scan* command from an application program.
3. Specify your scanning requirements in the ScanWizard DI control panel.
 - a) Select ADF (Simplex) in the *Scan Source* drop-down menu as your image input device.
 - b) Select the appropriate image type (e.g., Black & White) in the *Scan Type* drop-down menu as your image output type.
 - Select RGB Color (24 bits) to scan the image in color.
 - Select Grayscale (8 bits) to scan the image in grayscale.
 - Select Black & White (1 bit) to scan the image in black-and-white.
 - c) Select a dimension in the *Paper Size* drop-down menu as your preview image size.
 - d) Select a desired resolution in the *Resolution* drop-down menu for your image output resolution.
 - e) If “Auto-crop & Auto-deskew” is selected, the scanner automatically detects the size of the original image, crops the full scan frame to fit the image, and removes unwanted black borders after the scan, as well as corrects the distorted image for proper alignment.
4. If necessary, check “Auto Document Rotation”, “Smart Document Enhancement”, “Remove Blank Page” or “Remove Punch Hole” to enhance the quality of the scanned images.
5. Select the image type (e.g., Text) in the *Attribute* drop-down menu as your image type.
 - Select Line Art to scan line art images (images in one color or in black-and-white, such as logos or mechanical blueprints).
 - Select Photo to scan color prints.
 - Select Text to scan text.
6. If necessary, adjust image quality by using the image correction tools.

Scan a Stack of Documents (cont.)

7. Click the *Scan* or *Scan To* button to start multiple-sheet, automatic scanning.

If you want to scan both sides of the documents through the ADF, follow the steps listed in the ArtixScan 1200DF User's Manual for details.

- If ScanWizard DI is launched from an image-editing program, the scanned image is delivered after the scan to your application, where the image can be saved, printed, or modified further.
- If ScanWizard DI is launched as a stand-alone program, the scanned image can be saved after the scan to a file, opened in an image-editing program, or sent to a printer.

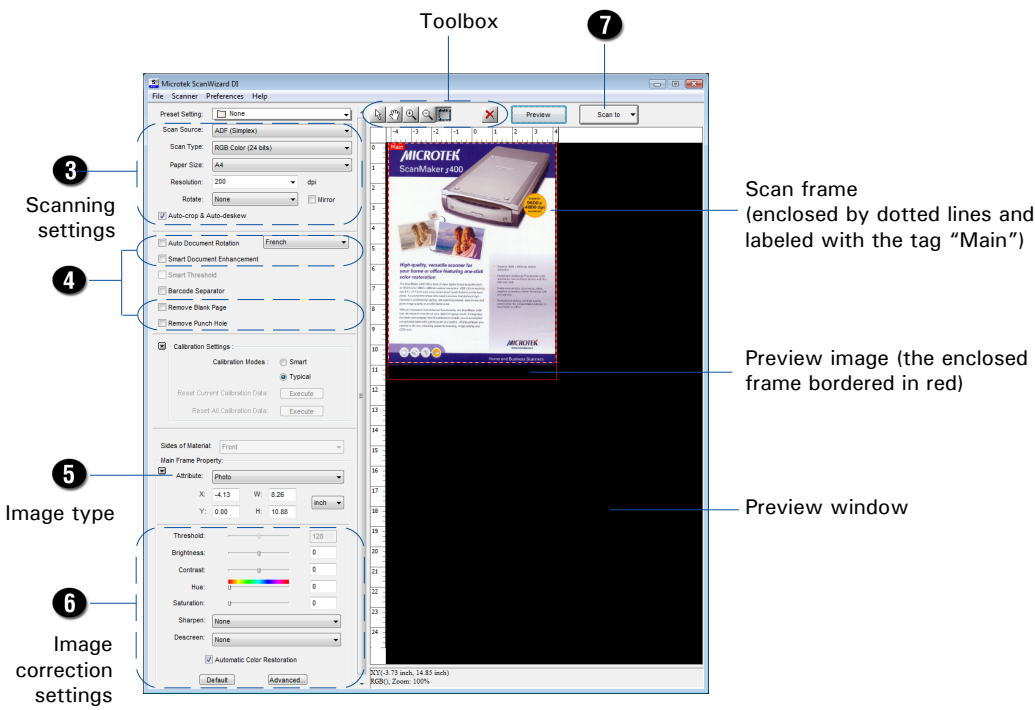
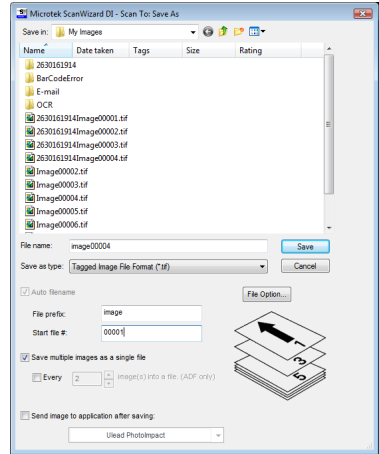

NOTE: For details on other scanning scenarios applicable to the ArtixScan 1200DF, refer to the ArtixScan 1200DF User's Manual.

Fixing Paper Jams

1. Open the ADF cover by lifting the two Earlobe Levers located on each side of the cover.

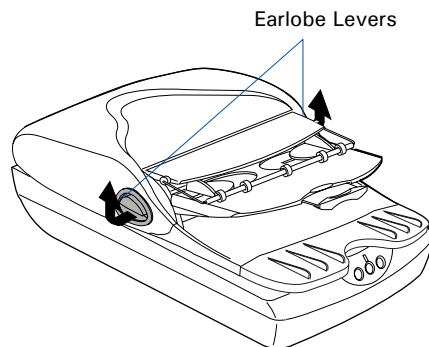

2. With the cover fully opened, pull out the jammed document from the feeder. If the paper is jammed in the first-stage (paper feed) rollers, pull the paper in a forward direction. If the paper is jammed in the second-stage (scanning) rollers, you may pull out the jammed paper in either direction (forward or backward).

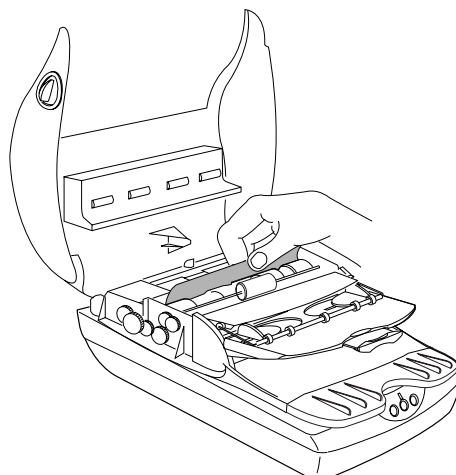

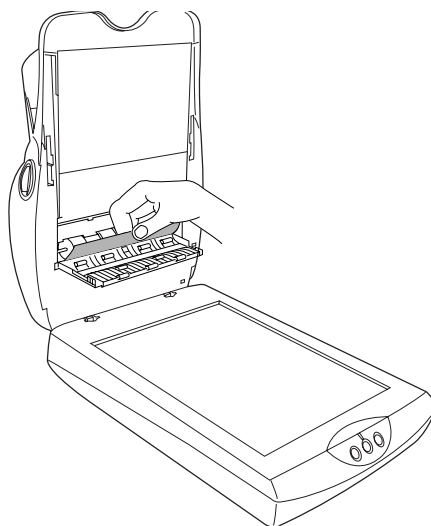

3. You can also open the cover of the scan sensor area at the bottom of the ADF to pull out the jammed piece of paper.



Problems?

The LED on the front panel of the scanner indicates the status of the scanner.

	On Ready to scan.
	Flashing Warming up of scanning.
	Off Scanner is off.

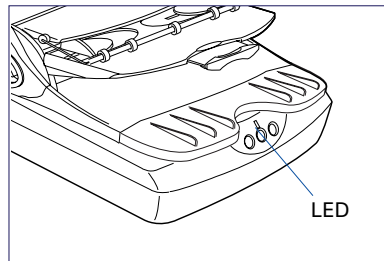

First, make sure that you have followed Steps 1 to 4 as described in this guide (unpack, install, unlock, connect). Then if your problem is listed here, try the suggested solution.

1. No light comes on when the scanner is turned on.

Make sure your scanner is connected to your computer and plugged into a power source.

2. The Add/Remove Hardware Wizard appears on your screen.

Click the "Cancel" button and close the ScanWizard DI Control Panel. Disconnect the Hi-Speed USB cable from the back of your computer, and refer to the installation instructions in this guide or the ArtixScan 1200DF User's Manual.

3. When trying to scan, an error message appears on your screen that reads, "Can't Find Scanners".

Make sure your scanner is unlocked (see Step 3).

Make sure your scanner is connected to your computer and plugged in to a power source (see Step 4).

Uninstall and reinstall the ScanWizard DI software.

4. After clicking scan, a blank screen appears.

Make sure your scanner is unlocked (see Step 3).

Uninstall and reinstall the ScanWizard DI software.

5. When trying to scan with the ADF (Auto Document Feeder), an error message appears on your screen that reads, "Code -206, ADF paper jam or roller failure."

Click OK first; then open the ADF cover, as illustrated in the previous section "Fixing Paper Jams".

- If the problem is occurring from a paper jam, follow the procedures laid out in the "Fixing Paper Jams" section of this guide.
- If the problem is occurring from situations other than a paper jam, follow the procedures laid out in the "Position a Stack of Documents" section.

Finally, close the ADF cover and restart scanning.

Do You Need Assistance?

Manuals

If you have additional questions and need further instruction or information, we provide electronic manuals for:

1. Using your ArtixScan 1200DF Scanner
2. Using the ScanWizard DI scanning software

To access the electronic manuals: Insert the scanner's software CD/DVD into your computer's CD/DVD-ROM drive. Next, locate and click the "Manuals" option when the software installer window appears on your screen. Finally, select and click the title of the manual you wish to view.

Missing Items

If your package is missing items, please call the Microtek Customer Service Department.

Drivers & Software Upgrades

After you finish the installation of software, if you found that the installed drivers and software cannot run your product or your computer system properly later, please go to the Microtek **Download Service** site at ww7.microtek.com.tw/service.php to download and install any updates you may require.

For additional information about Microtek products, please visit our website at www.microtek.com.

Power Adapter

Use only power supplies (AC/DC adapters) listed below:

Voltage	Manufacturer	Model No.
100V to 240V	WUXI HARD	HDAD38W101

NOTE: Please make sure that the electrical outlet to where the scanner will be connected is nearby and readily accessible.

Copyright © 2013 Microtek. Microtek, ScanMaker, ArtixScan, ScanWizard and ColoRescue are trademarks or registered trademarks of Microtek International, Inc. All other trademarks or registered trademarks are the property of their respective holders. Specifications, software and hardware bundles are subject to change without notice. Delivery of technical support services subject to change without notice. Not responsible for typographical errors.



この装置は、クラスB情報技術装置です。この装置は、家庭環境で使用することを目的としていますが、この装置がラジオやテレビジョン受信機に近接して使用されると、受信障害を引き起こすことがあります。

取扱説明書に従って正しい取り扱いをして下さい。 VCCI-B